

Series
SS-SSM (ø58mm)
SMS-SMM (65mm)
STS-STM (90mm)

Serial Encoder Synchronous SSI



Mechanics Data

Cover:	Aluminium
Body:	Aluminium
Solid shaft:	Stainless steel
Bearings:	2, ballraces
Weight:	350gr. (single turn) 500gr (multiturn)
Protection:	IP65
Rpm:	3000 Max
Torque:	5Ncm
Inertia:	100gcm ²
Shaft loading:	Axial 50N - Radial 50N (max value)

Dimensioni in millimetri

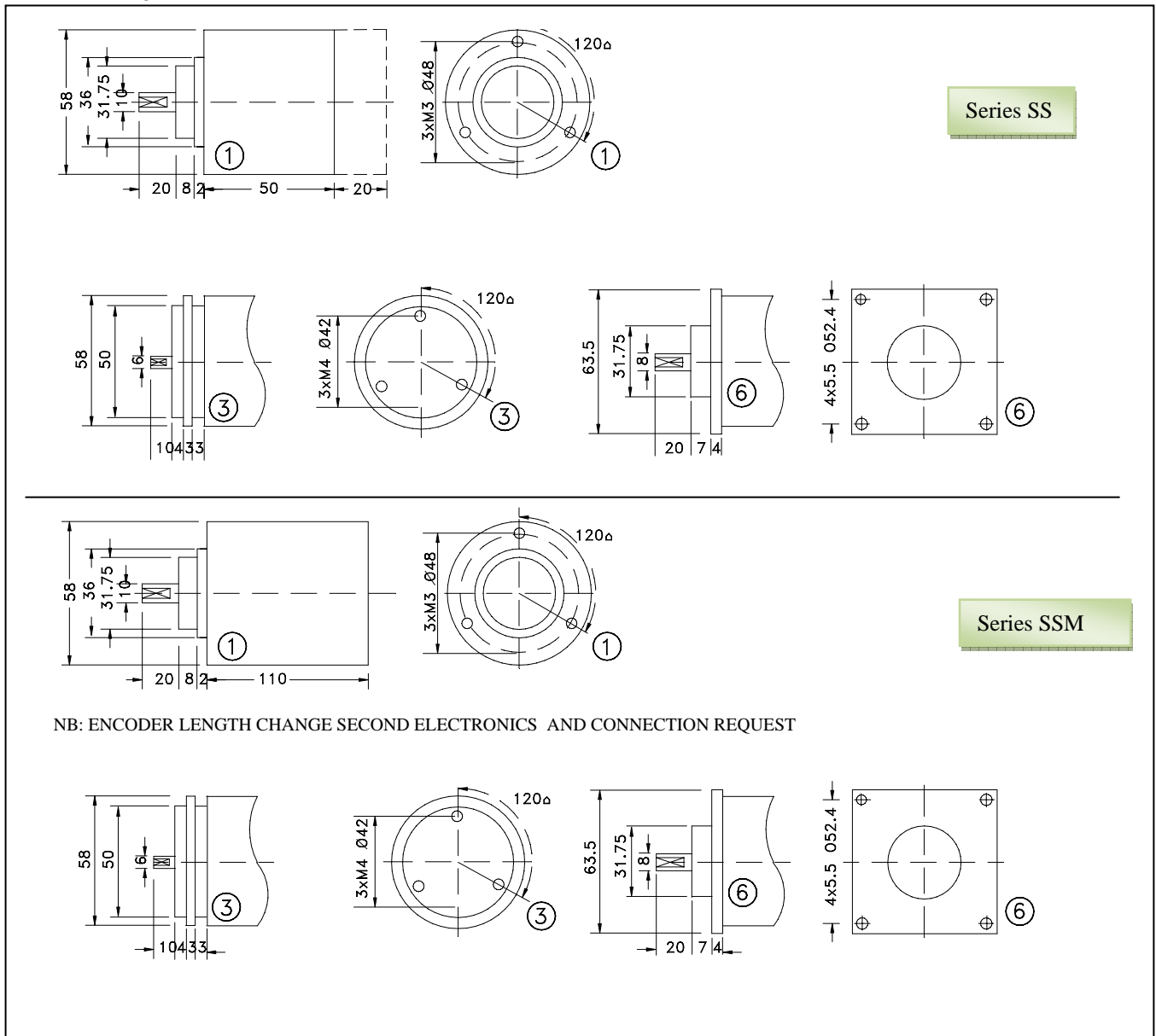

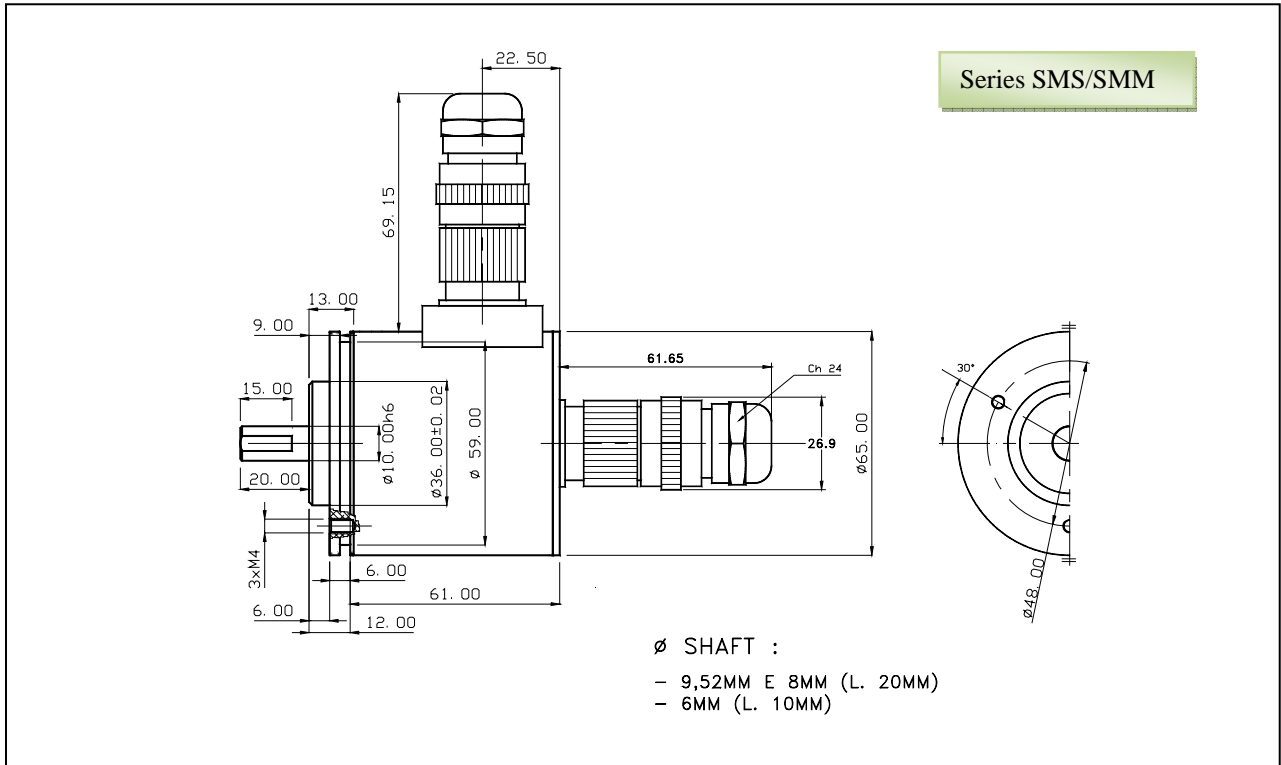

Length of body: Series SMS = 61.00 / SMM = 103.00

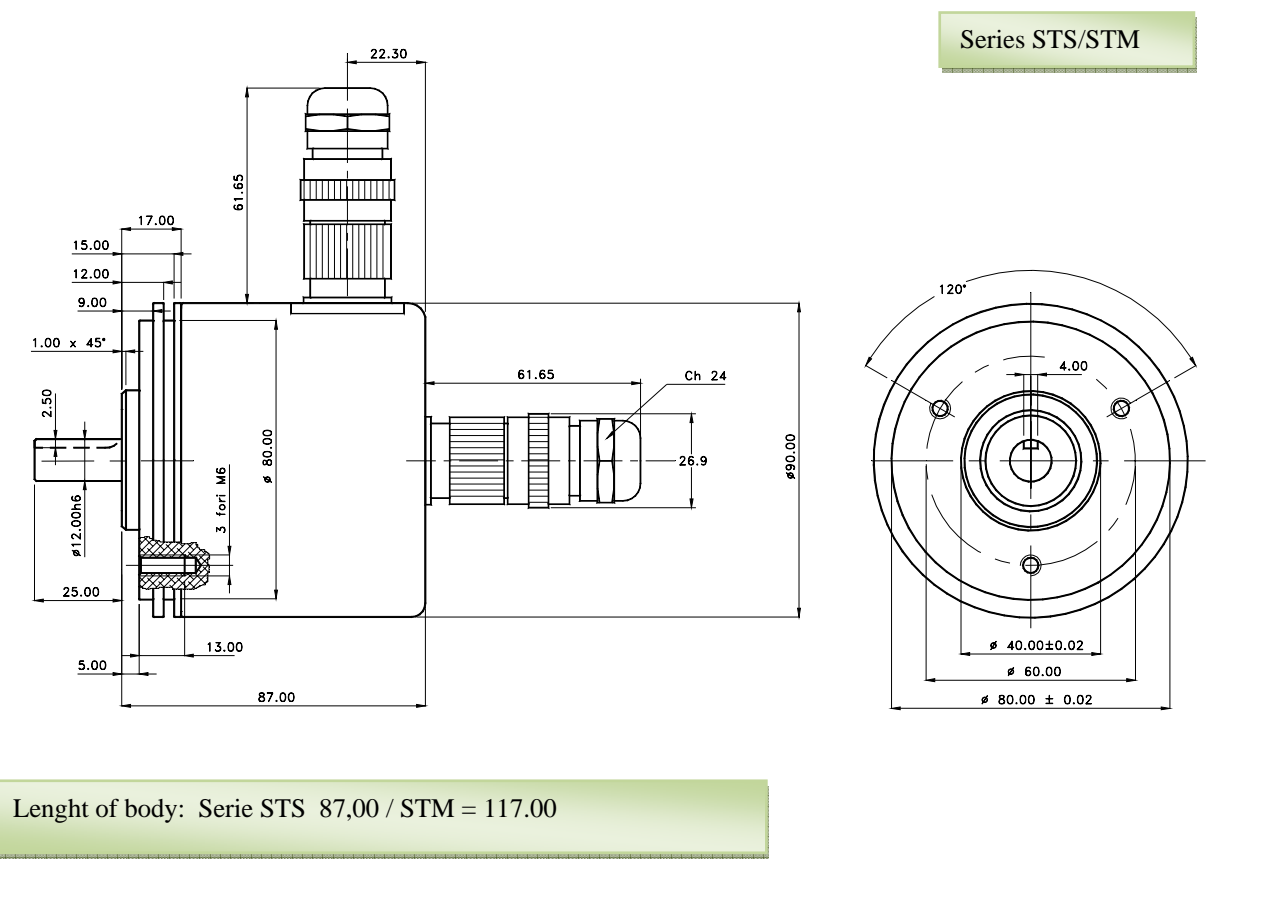

Series
SS-SSM
(\varnothing 58mm)
SMS-SMM
(\varnothing 65mm)
STS-STM
(\varnothing 90mm)

Electronics Data

Resolution: Single turn 13 Bit
Multiturn 24 bit (12 Bit single turn - 12 bit multiturn)
Power supply: 11-24V +/- 5%
Current consumption: Single turn 3Watt max.
Multiturn 6 Watt max.
Input : Opto-coupler balanced in RS422 (Clock)
Synchronism frequency: 80KHz-1MHz
Outputs: Differential in RS422
Programmable Code: Gray/Binary
Programming: Line in RS232
Operating Temp.: 0/60°C

Output circuits

Output Driver RS-422

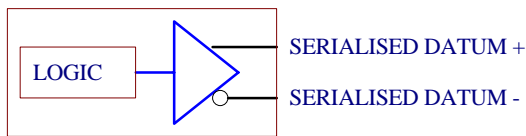

Input circuits

Synchronisation Clock Input

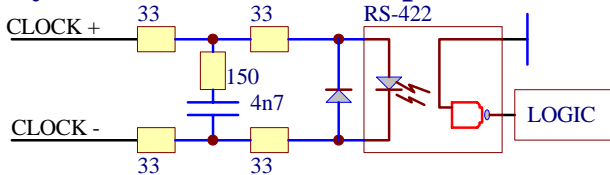

Programming Bit Input

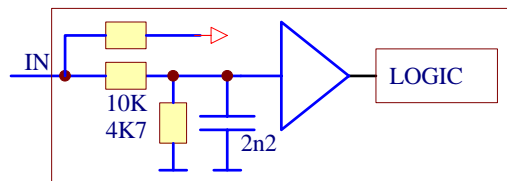

Data transmission

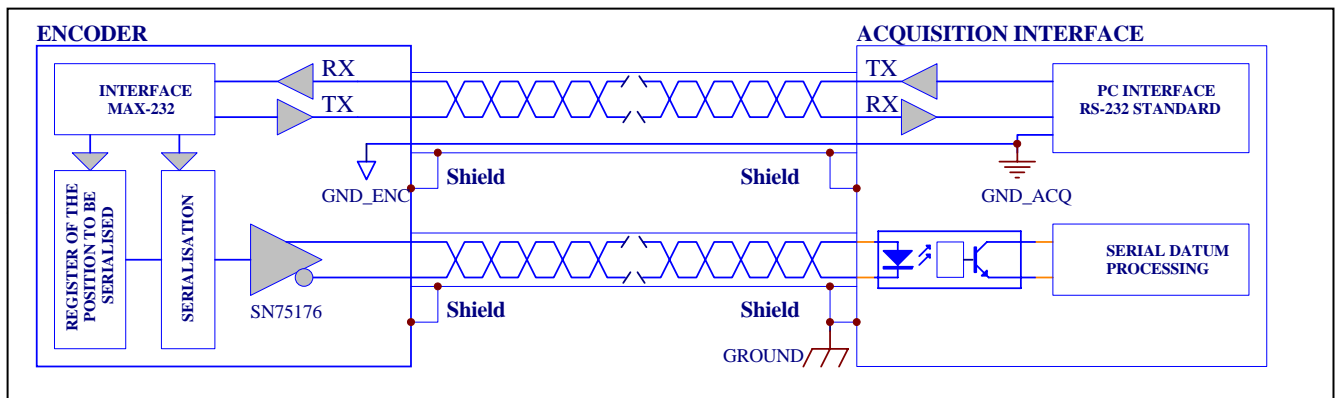

Ordering code

*	*	*	-	*	*	*	*	/	*	/	*
Series				Shaft	Flanges	Outputs	Connections	Options	Pulses/Turn		
Ø58mm SS = Singleturn SSM = Multiturn				Ø58mm 3=Ø 6mm L10mm 6=Ø 8mm L20mm 1=Ø10mm L20mm	Ø58mm 1=See 3= page 6= draw	1=RS422 RS485	1=9416 Axial 2=9416 Rad. 9= Axial cable 3= Radial cable	0=None			
Ø65mm SMS = Singleturn SMM = Multiturn				Ø65mm 3=Ø 6mm 10mm(SMS) 6=Ø 8mm L20mm (SMS) 1=Ø10mm L20mm	Ø65mm 3=Ø 65mm						
Ø90mm STS = Singleturn STM = Multiturn				Ø90mm 1=Ø 10mm L25mm 2=Ø 12mm L25mm	Ø90mm 3=Ø 90mm						

CABLE		Contact 12P IP65		<i>Connections</i>	
Pink	1	CLOCK +		Clock +	
Pink/Gray	2	CLOCK -		Complementary clock +	
Brown	3	DATA S. +		Data +	
Brown/Gray	4	DATA S. -		Complementary Data +	
Blue	5	PROG_TX		Programming Input	
Blue/red	6	PROG_RX		Programming Input	
Beige	7	BIN/GRAY		Binary and Gray (active low)	
Violet	8	UP/DOWN		Up/Down (active low)	
Yellow/White	9	PSET 1	RESET	1 Preset (active low)	Reset
Yellow/Brown	10	PSET 2		2 Preset (active low)	
Red	11	POWER +		Power + (11-24V)	
Black	12	POWER. -		Power - (0V)	

In configuration standard, the encoder is: 12 Bit (singleturn) or 24 Bit (multiturn) of resolution, Parity inactive, increase clockwise and Binary code.
 The programming encoder parameter, effect in RS232 with a module for PC supply in equipment.